

# Commercial Generator Set Standard Diesel™ Series SD 20 kW 60 Hz



## Cummins Onan

Performance you rely on.™



### Features and benefits

- Low vibration for smooth operation
- Powerful 40 hp engine
- User-friendly remote control option
- Bottom mounted radiator for increased cooling efficiency and smaller package size
- Complete, integrated package for easy, low-cost installation
- Integrated muffler for added quietness and ease of installation
- Service and maintenance points easily accessible (single-side)
- Engine meets interim Tier IV emissions
- Excellent motor starting capability
- Bulkhead fuel and battery connections
- Single side cooling air inlet, bottom cooling air discharge
- Field Effect Transistor (FET) control
- Electronic governing for precise frequency control
- Less than 4% total harmonic distortion at full load
- SAE J1939 CANbus output
- Engine oil cooler
- Multiple fuel and battery block mounting locations

### Weight, size and sound level

**Weight:** 890 lb (404 kg)

**Size:** Length 48.9 in (1241 mm), width 23.6 in (600 mm), height 27.9 in (708 mm)

**Sound:** 60 Hz (single phase) 81.9 dB(A) at 10 ft (3 m) before installation, full load

### Models and ratings

Model	Fan	Hz	Watts	Voltage	Amps	PF	Phase	Circuit breaker
<b>20HDKAW-2008A</b>	Scroll*	60	20000	120/240	166.67/83.33	1.0	1	2-pole, 85 A

- All 60 Hz models operate at 1800 r/min.
- Ratings apply up to 500 ft (152.4 m) altitude, 85 °F (29 °C) ambient with No. 2 diesel fuel.
- Maximum power capability decreases 3.5% for each 1000 ft (305 m) above 500 ft (153 m) and 1% for each 10 °F (5.5 °C) increase in ambient temperature above 85 °F (29 °C).

\*DC compartment cooling fan supplied with generator set.

---

## Standard features

- 4-cylinder diesel engine
- Brushless alternator
- Semi-focalized mounting system with 4-point vibration isolation
- Bottom mount radiator
- Drip catcher for oil filter replacement
- Vertically mounted fuel filter, spin on cartridge
- Replaceable element air cleaner
- Multiple exhaust options
- Exhaust air directional vane available
- 30 A battery charging DC alternator
- Single point lifting bracket
- Automatically timed glow plugs for easy starting
- Base pan for drip control
- Electric fuel pump (prime mode available)
- Side air inlet, bottom air outlet
- Spark arresting muffler
- Bulkhead type connections for fuel and battery
- Service and maintenance points easily accessible (single-side)
- Instant one-touch stop
- Over voltage, low oil pressure, over temperature, over speed and over load safeties
- Vibration isolated control box
- Oil drain and fill standard on service side

## Typical fuel consumption

No. 2 diesel fuel, Gal/hr (L/hr)	No load	Half load	Full load
20HDKAW	0.54 (2.04)	1.12 (4.24)	1.95 (7.39)

---

## Alternator details

**Design:** Cummins Onan brushless, revolving field, 4-pole, rigidly coupled to engine and permanently aligned.

**Insulation system:** Class H per NEMA MG1, Section IV, Part 32, Paragraph 32.6 and Table 32-3.

**Exciter system:** Brushless with 8-pole stator mounted in endbell; rotating rectifier assembly is encapsulated for protection from adverse environments.

**Cooling:** Direct drive centrifugal blower.

**Rotor:** Dynamically balanced assembly; directly coupled to engine by flexible drive disc; supported by pre-lubricated, maintenance-free ball bearing.

**Stator:** Skewed stator and 2/3 pitch windings minimize field heating and voltage harmonics; resin coated for corrosion protection.

	No load/full load	Constant load
<b>Voltage regulation:</b>	±1%	±0.6%
<b>Frequency regulation:</b>	±0.5%	±0.5%

## Engine details

**Model:** Kubota V2403-M

**Design:** 4-cycle, liquid-cooled diesel engine

**Cylinders:** 4, inline vertical

**Bore:** 3.43 in (87.0 mm)

**Stroke:** 4.03 in (102.4 mm)

**Displacement:** 148.5 in<sup>3</sup> (2434 cm<sup>3</sup>)

**Compression ratio:** 24.3:1

**Lube oil capacity:** 2.51 gal (9.5 L)

**Power (max):** At 1800 r/min: 40 hp

**Cooling system capacity:** 1.95 Gal (7.4 L)

**Starting system:** Remote, 12 V

**Fuel injection pump:** Bosch

**Combustion chamber:** Spherical vortex three combustion system

**Motor starting:** This genset is capable of delivering 50 kVA at rated voltage (120/240) for motor starting. To find the kVA load requirement, multiply locked rotor amps (LRA) x nominal voltage to get motor requirement kVA. If this value is less than 50 kVA, this genset will start that motor.

---

## Generator set details

### Control

- Unit mounted, drip-proof, vibration isolated console
- Electronic control with self diagnostics and generator set protection and safety features included.

### DC controls, 12 V system

- Start/stop/preheat/prime switch
- Remote connector for start/stop/preheat switch and gauge package
- Hour meter

### AC controls

- Electronic voltage regulator

# Basic dimensions

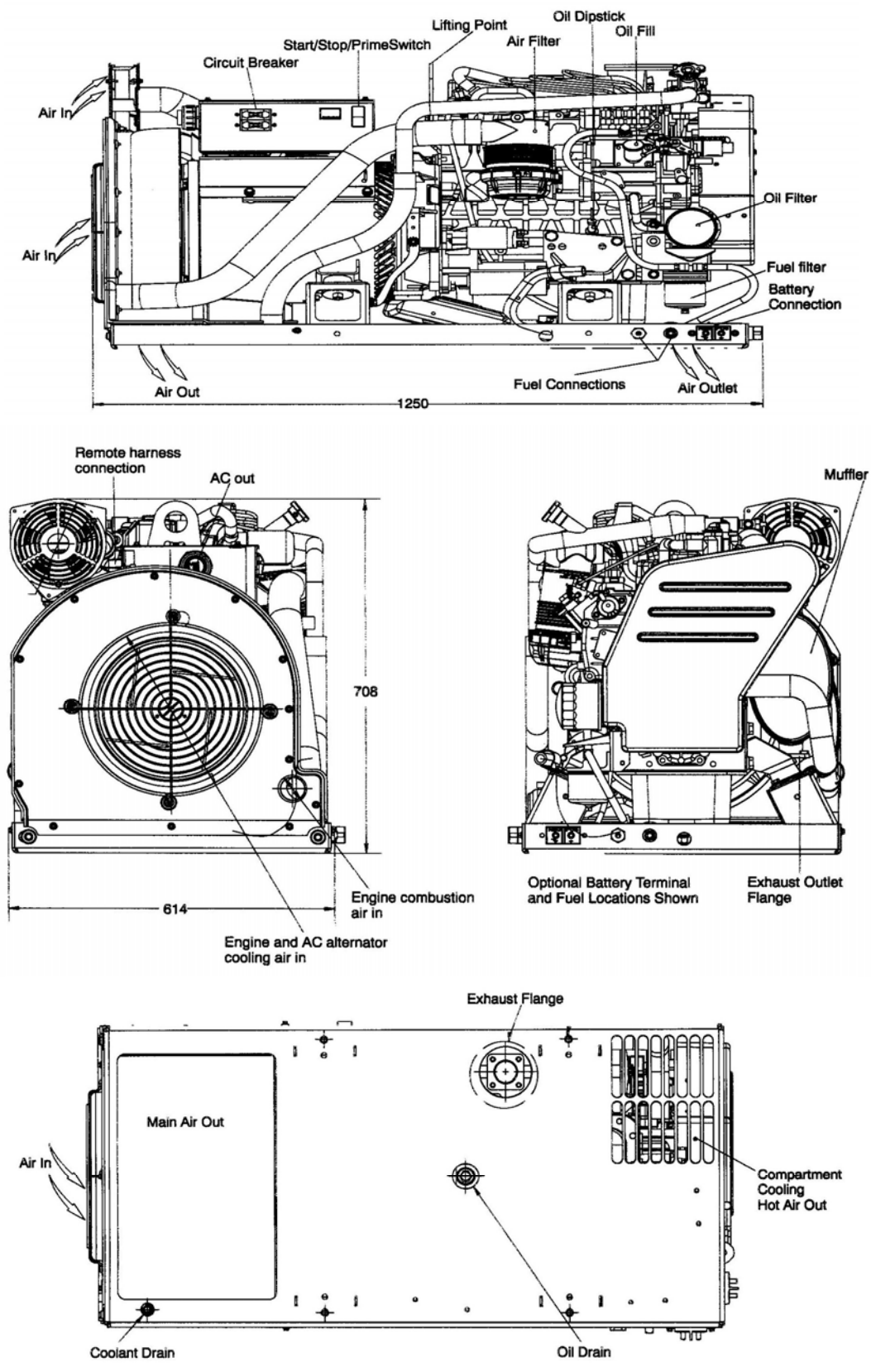

**Note:** This outline drawing is provided for general reference only and is not intended for design or installation. For more information see Operation and Installation manuals or obtain drawing A026K862 and wiring diagram from your distributor/dealer.

---

## Options and accessories

- Remote control panel, switch only (P/N 300-4942)
- Remote control panel, switch and hour meter (P/N 300-4943)
- Remote control panel, switch and DC voltmeter (P/N 300-4944)
- Exhaust down tube (P/N 0155-4976)
- Exhaust up tube (P/N A026D359)
- Exhaust side tube (P/N A028W811)
- Cooling air outlet vane (P/N A028V210)
- Remote harness (for use with above panels), 10 ft (P/N 338-3490-01), 30 ft (P/N 338-3490-02)
- Remote harness pigtail at set (P/N 300-4947)
- Remote harness pigtail at panel (P/N 338-3573)

---

## Standards and testing

- Tested at extremes of temperature -20° F (-29° C) to 104° F (40° C) for starting and operation
- Tested with commercial loads
- Tested in high humidity conditions
- Tested in salt spray conditions
- Tested in heavy airborne dust conditions
- Field test program
- This product meets U.S. interim EPA Tier IV and EU Stage 3A for emissions
- This generator set was designed and manufactured in facilities certified to ISO 9001



## Warranty policy

The Cummins Onan limited warranty covers virtually everything except routine maintenance for the first two years you own your generator set, or the first 2,000 hours of operation, whichever comes first. In addition, it includes a free 90-day adjustment policy, which provides that Cummins Inc. will make minor adjustments to your new generator set during the first three months you own it - free of charge!

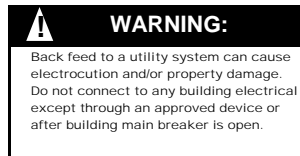
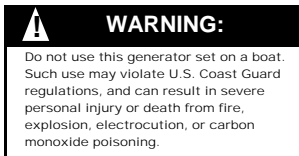

---

## After sale support

### Largest distributor/dealer support network

Cummins Onan generator sets are supported by the largest and best trained worldwide certified distributor/dealer network in the industry. This network of knowledgeable Cummins Onan distributor/dealers will help you select and install the right generator set and accessories to meet the requirements of your specific application. This same network offers a complete selection of commonly used generator set maintenance parts, accessories and products plus manuals and specification sheets. Plus, they can answer your questions regarding proper operation, maintenance schedules and more.

**Manuals:** Operation and installation manuals ship with the generator set. To obtain additional copies or other manuals for this model, see your Cummins Onan distributor/dealer and request the following manual numbers: Operation (A026M828), Installation (A026M829), Parts (A029U222), Service (A028W414).

To easily locate the nearest Cummins Onan distributor/dealer in your area, or for more information, contact us at 1-800-888-6626 (or 763-574-5000), or visit [www.cumminsonan.com](http://www.cumminsonan.com).

---

## Contact your distributor/dealer for more information

# Cummins Onan

### Cummins Power Generation

1400 73rd Ave. NE  
Minneapolis, MN 55432 USA  
Phone 1 763 574 5000  
Toll-free 1 800 888 6626  
Fax 1 763 574 5298  
Email [www.cumminsonan.com/contact](http://www.cumminsonan.com/contact)  
[www.cumminsonan.com](http://www.cumminsonan.com)

